



# 545 Series

## 1200lbs Electromagnetic Lock

**Model**    **UL545-S (Unmonitored Version)**  
              **UL545-SL (Monitored Version)**



### Description

1200lbs EM locks were designed to meet fire/life safety applications by providing an auxiliary locking mechanism that has no moving parts to bind or wear out for trouble free operation. This will ensure inhibited release at all times where they have become extremely prevalent in applications other than fire/life safety. Suitable for interior & perimeter doors which requires medium security.

### Standard Features



Life Safety Applications

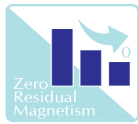

No Residual



Low Energy Consumption



Cost Savings

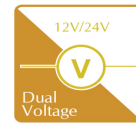

12/24V Selectable



Ideal for all door type

### Extended Features

(Optional)

- Lock Status Monitoring
- Electroless Nickel (EN) Plated Armature Plate
- Instantaneous release with in-built electronic device
- Anodized Aluminium Housing
- CE Compliance

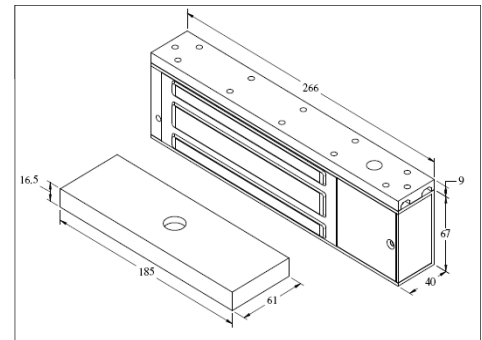

### Specification

	UL545-S / UL545-SL
<b>Magnet Size</b>	266 X 67 X 40 mm
<b>Armature Size</b>	185 X 61 X 16.5 mm
<b>Holding Force</b>	Up to 1200lbs
<b>Current Drain</b>	420mA±10%/12Vdc / 210mA±10%/24Vdc
<b>Temperature</b>	(-10 to 55)°C (14 to 131)°F
<b>Weight</b>	4.71kg

### Wiring Diagram

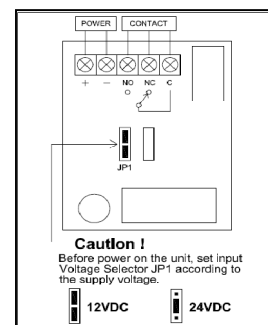

**WARRANTY:-** Algatec EM Lock are warranted against defects in material and workmanship while used in normal service for a period of 5 years from the date of sale to the original customer.

**DISCLAIMER:-** Specifications are subject to change without prior notice.

- Attached photo is for reference purpose only, actual product may varies.

